



DOMS CONCENTRIC with Centric chair and desk 1300x650mm

**DOMS CONCENTRIC** meets the high quality standards imposed by the DOMS philosophy:

- Solid construction
- Components of best quality
- Precise processing – down to the last detail
- Ergonomic design with useful functional characteristics

**DOMS CONCENTRIC** is the practical alternative to the telescope sliding table. Complete diagnosis and refraction in compact form.

The 2- instruments swivelling table with ergonomic motion (guided in path), cushioned end points and magnetic locking can be brought manually into the working position.

The classical "Pendulum Phoropter Bracket" can be brought simply in front of the patients – smooth running by a supporting gas tension spring. The "Pendulum Phoropter Bracket" with forth and back movement by electric drive is still more comfortable.

**DOMS  
CONCENTRIC**



**Pendulum-Phoropter Bracket**  
manually operated  
(Option with electric drive)



**Handle for ergonomic motion**  
of the swivelling instruments table.



**Container,**  
2 pull-out drawers (with feed damper)  
(a lot of storage space e.g. for small parts  
and Reading Charts), below box for  
Tower PC.



**Halogen-Spotlight 20 W**  
The on/off switch is integrated into column,  
pull-out lamp head.



**Control Panel illuminated, Hand-held  
Instrument storage**  
handily placed, switching functions at the  
front side of the column: Unit on/off,  
chair automatic down, upgradeable with  
5 additional keys e.g. Work Place Lamp,  
curtain up/down (open/closing), Fixation  
light, Maddox Cross, rheostat for hand-held  
instrument storage.



**Drawer for Trial Lenses,**  
swivel-mounted, for „large“ trial lens set max.  
247 lenses / broad rimmed.



**Big Work Place Lamp**  
adjustable hinge, 15 W fluorescent lamp.



**Spectacle Storage**  
for Patient Glasses, besides the patient  
chair.



**Small Desk Top ca. 650 x 700mm (e.g.  
Multiplex "beech").**

**Standard Desk 1300x 650mm,**  
open storage shelf, stable pedestal (L-De-  
sign) , swivelling drawer for trial lenses  
(for „large“ trial lens set max. 247 lenses /  
broad rimmed).

Extensive colour selection according to RAL  
color card, also Multiplex „beech“ or  
Real wood veneer. For maximum workload  
with minimal maintenance there are mineral  
substances (Natural Acrylic Stone) of well  
known manufacturers.



### Patient chairs line CENTRIC

Electromotive height control, timeless classic design, high backrest, neck pad (head rest) adjustable via integrated holding magnets (type Centric excite) or with adjustable leverage (type Centric) Optional: Tilttable backrest, manual or electromotive seat adjustment, armrest pivotable backwards, foot rest and calf pad pivotable upwards, upper part of chair turnable 360° with detent at 45° and each 90°, durable elastic quality synthetic leather in attractive colours appropriate for wiping disinfection.

CENTRIC excite

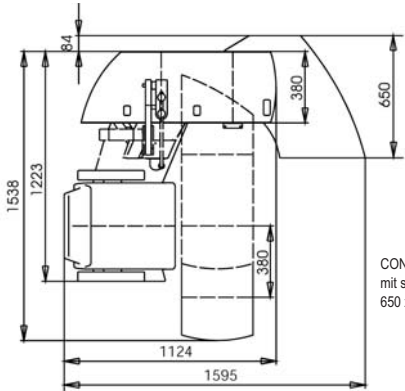

CONCENTRIC  
mit small desk top ca.  
650 x700 mm

(dimensions in mm)

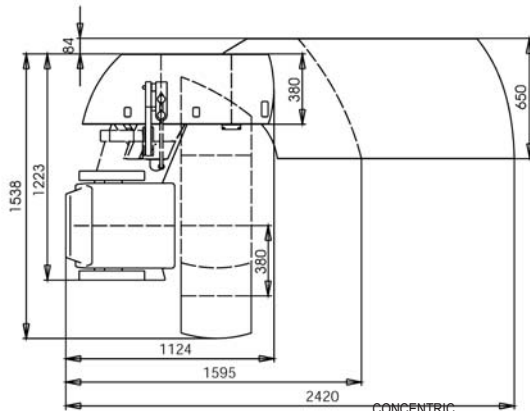

CONCENTRIC  
with standard desk  
1300x650mm

Distributor:



Medical Device Directory / product class: 1  
Certified according to  
Quality Management System DIN EN ISO 9001:2000

Technical Data:

DOMS CONCENTRIC  
incl. 2-instruments swivelling table

Height: 1750 mm (w/o chart projector / LCD screen)  
Length: 2420 mm (standard desk)  
Width: 1223 mm  
1538 mm (2-instruments table moved into position 2)

Height of instruments table: 860 mm  
Patient chair CENTRIC  
Minimal height of seat: 470 mm\*  
Maximal height of seat: 670 mm\*  
Lifting power: 1500 N  
Connecting voltage: AC 230 V 50/60 Hz  
Power: 1000 VA  
Voltage supply (table instruments):  
Low voltage: 6 V/12 V  
Non-heating connector: 230 V  
Protection (unit) : IP 20 / Class I

(\*height of patient chair incl. seat upholstery)

Subject to alterations in form and design  
without prior notice.

design – made by doms eye-technology –  
engineered + made in Germany

### DOMS EYE-TECHNOLOGY GmbH & Co. KG

Carl-Zeiss-Strasse 5 D-07318 Saalfeld  
Fon: +49 (0) 3671/5450-0  
Fax: +49 (0) 3671/5450-20

info@doms.eu www.doms.eu

Edition 03/10



## DOMS CONCENTRIC

CLASSIC SWIVELLING TABLE UNIT  
WITH PENDULUM PHOROPTER BRACKET  
COMPACT AND FUNCTIONAL